



471 INDUSTRIAL AVE.
RIPON, CALIF. 95366
PHONE (209) 599-6118

JACKRABBIT
SERVICE PARTS
30/36 ELEVATOR
with
WOODCHUCK DESTICKER



10/18/10

Phone (209) 599-6118 Fax (209) 599-6119
E-mail sales@jackrabbit.bz or info@jackrabbit.bz

TO OUR CUSTOMERS:

Thank you for choosing JackRabbit. We stand behind our products and are very proud of the equipment we design and manufacture. Preventive maintenance is the easiest and least expensive type of maintenance. Please take the time to review this Owner's Operator's Manual it can save you time and expense.

WARRANTY

JACKRABBIT warrants each new piece of equipment and parts manufactured by it to be free from defects in material and workmanship under normal use and service. The obligation of JACKRABBIT shall be limited to replacing any part which shall, within 1 year (1 season) after delivery to the original purchaser, be returned to JACKRABBIT with transportation charges prepaid and which an examination by JACKRABBIT discloses defective. This Warranty does not obligate JACKRABBIT to bear the cost of labor, travel time or hauling in connection with the replacement or repair of the defective parts and in no event will be liable for consequential damages including but not limited to loss of crop, rental or substitute equipment or other commercial loss.

No warranties or representations made by persons other than representatives of JACKRABBIT expressly authorized in writing to do so shall be valid and binding upon JACKRABBIT. No dealer shall be authorized to bind JACKRABBIT in this respect. JACKRABBIT makes no warranty with respect to component parts not manufactured by JACKRABBIT. This warranty shall not apply to any equipment which has been altered in any way outside of manufacturer's factory, or which has been subject to misuse, neglect or accident.

This warranty is expressly in lieu of all other warranties and representations, expressed, implied, or statutory, including warranties of merchantability and fitness for a particular use, and all other liabilities or obligations on the part of JACKRABBIT, foreseeable or not.

USER'S RESPONSIBILITY

It is the responsibility of the user to read the Operator's Manual and understand the safe and correct operating procedures as pertains to the operation of the product and to lubricate and maintain the product according to the maintenance schedule in the Operator's Manual.

WARRANTY SERVICE

Warranty service may be obtained through an authorized dealer or JackRabbit service facility. Write or call: JackRabbit, 471 Industrial Ave, CA 95366, telephone (209) 599-6118

TABLE OF CONTENTS

| | Page |
|---|----------------|
| A. Incline conveyor section | 1 - 4 |
| B. Bin conveyor section | 5 - 6 |
| C. Engine section | 7 - 10 |
| D. Electrical schematic, gauges & switches | 11 - 12 |
| E. Hydraulic schematic & parts 30/60 | 13 - 14 |
| Hydraulic schematic & parts 30/60 with WoodChuck | 15 - 17 |
| F. Bearings list | 18 |
| G. Belt list | 18 |
| H. Decals list | 18 |
| I. Miscellaneous parts list | 18 |
| J. WoodChuck Desticker | 19 - 25 |
| K. Front Wheel Drive Option | 26 - 29 |

PARTS LIST

| ITEM # | PART # | DESCRIPTION | SERIAL# | REQD. |
|---------------------------------|---------------|---|----------------|--------------|
| INCLINE CONVEYOR SECTION | | | | |
| 1 | 26034 | Incline Conveyor Motor (OMT500) | | 1 |
| 2 | 25996 | Upper Torque Arm | | 1 |
| 3 | 27352 | Clamping Collar | | 1 |
| 4 | 26812 | Coupler Solid 1-1/2" ID | | 1 |
| 5 | 22097 | Bearing (1-1/2" Pillow Block) | | 2 |
| 6 | 28441 | Upper Drive Pulley 36" W/LG. & Shaft | | 1 |
| | 28443 | Shaft 1 1/2" | | 1 |
| 7 | 28440 | Snub Roller 36" Length | | 1 |
| | 28439 | Shaft only for snub roller | | 1 |
| 8 | 23524 | Flangette Bearing (52 MST 22PPRAG) for snub roller | | 2 |
| | 23524A | RA 100 RRB COL AG Bearing | | 2 |
| 9 | 28892 | 36" x 64' 6" Giant Z Incline Belt (Standard Model) | | 1 |
| | 29131 | 36" x 70' 6" Giant Z Incline Belt (3' Extension) option | | 1 |
| | 27523C | 36" Lacing pin | | 1 |
| 10 | 28506 | Idler Roller 36 – 3/8" Length, Return Roller | | 6 |
| 11 | 27307 | Bearing Housing For Return Rollers (End Cap) | | 12 |
| 12 | 27306 | Bearings for Return Rollers | | 12 |
| 13 | | Shaft & #21 Spring for 36 3/8" Return Roller | | 6 |
| 14 | 28936 | Belt Wipers (UHMW) 36" Incline Belt | | 2 |
| 15 | 22977 | Bearing (1" Pillow Block) | | 2 |
| 15B | 31067 | Bearing for Incline Conveyor (RFC350 1 1/2") | | 2 |
| 16 | 28418B | Idler Pulley, Incline belt(36 " W/Lag) | | 1 |
| | 28418 | Idler Pulley Shaft | | 1 |

ITEM # PART # DESCRIPTION SERIAL# REQD.

INCLINE CONVEYOR SECTION 30/36

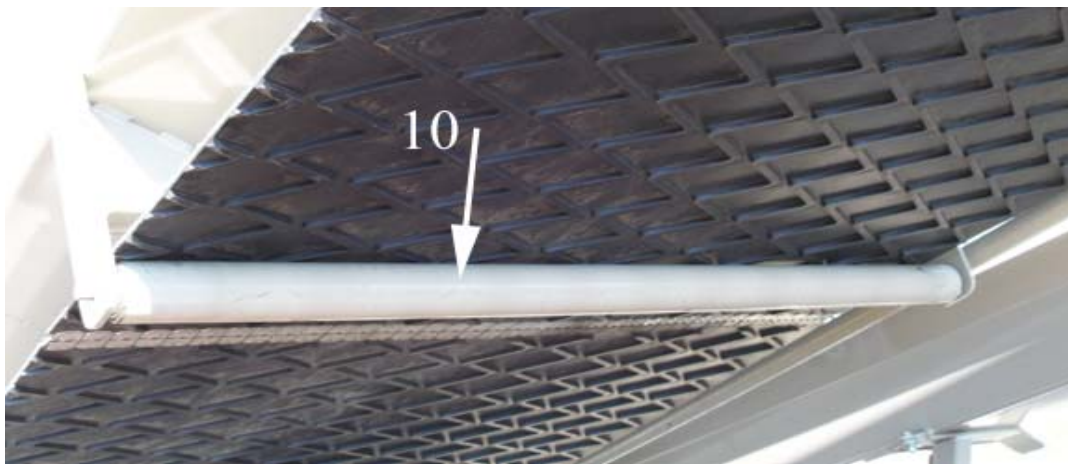
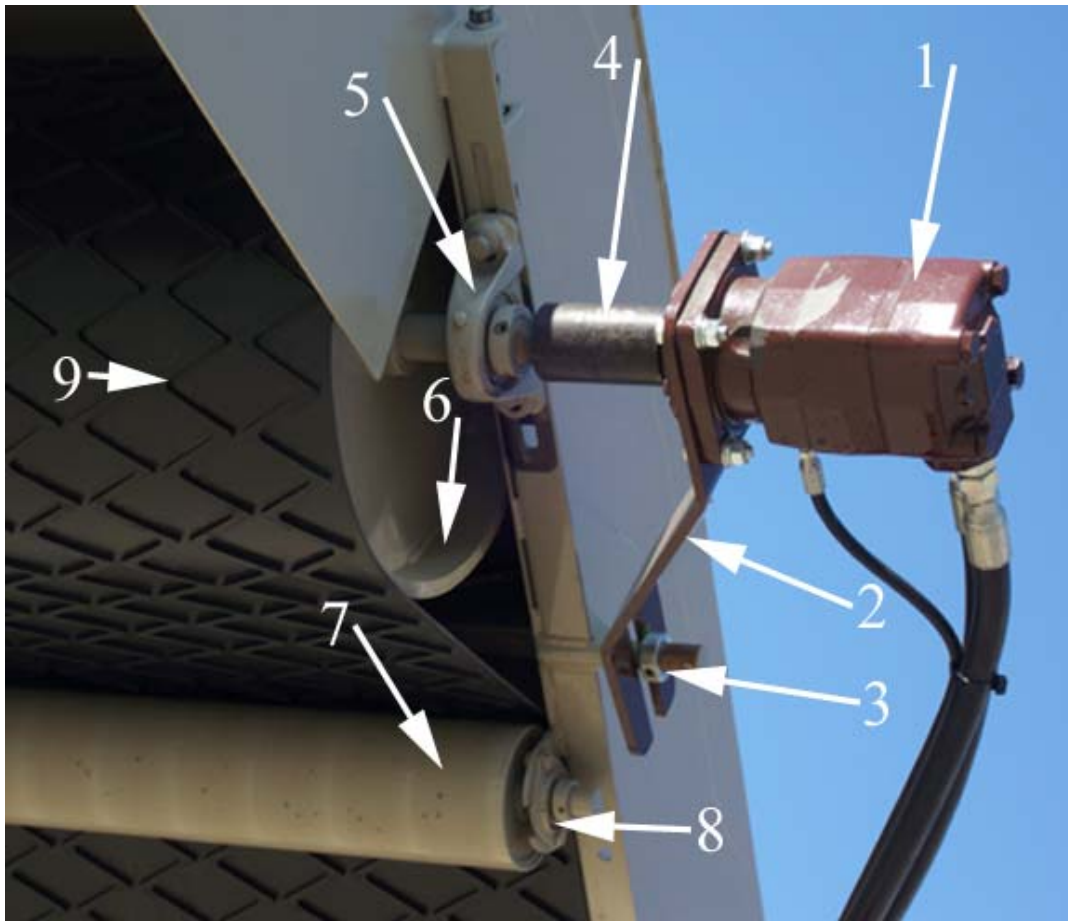

ITEM # PART # DESCRIPTION SERIAL# REQD.

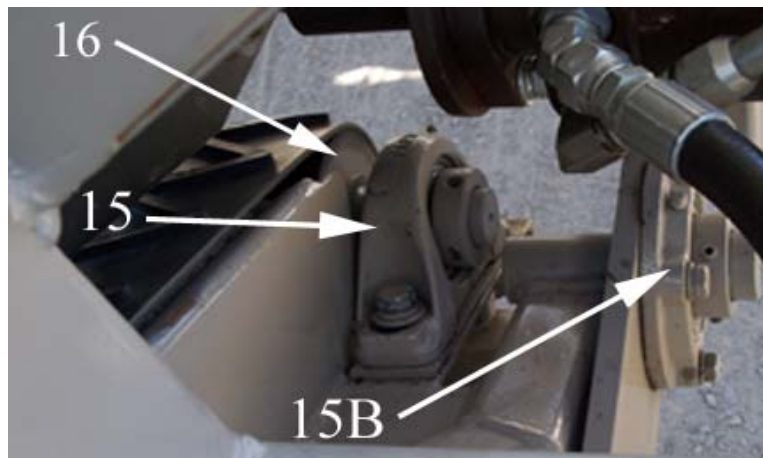
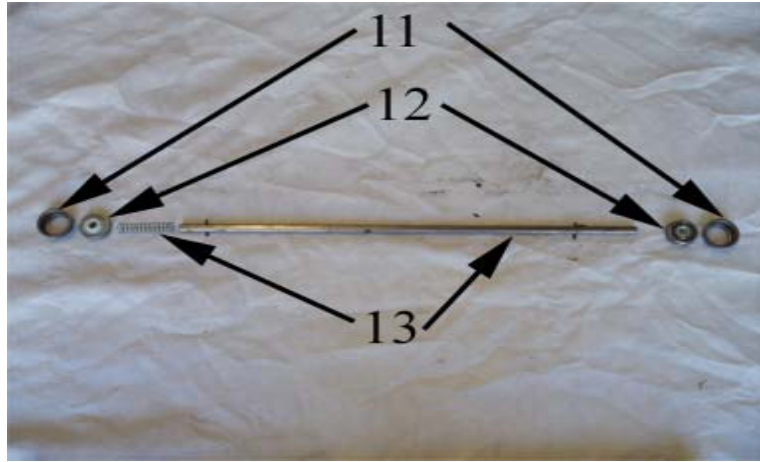

| ITEM # | PART # | DESCRIPTION | SERIAL# REQD. |
|-----------------------------|---------------|--|----------------------|
| BIN CONVEYOR SECTION | | | |
| 15 | 22977 | Bearing (1" Pillow Block) | 4 |
| 30 | 26464 | Bearings Pad | 2 |
| 33 | 28891 | (30" x 309") Giant Z Bin Belt | 1 |
| | 27523A | 30" pin for lacing | 1 |
| 33A | 26887 | Belt Wiper UHMW 37" | 1 |
| 33B | 28883 | Front Seal (for pop out) | 1 |
| 33C | 28934 | Transition Seal UHMW | 2 |
| 34 | 24664 | Lower Hyd. Motor (RS180201) | 2 |
| | 24664A | Seal Kit Motor for (RS180201) | 1 |
| 35 | 26493 | Motor Coupler (Climax Coupler CC100-100) | 2 |
| 36 | 28935 | Lower Torque Arm | 2 |
| 37 | 28832A | 30" Drive Pulley W/Lag | 2 |
| 60 | 26018 | Idler Roller 30 3/8" (return roller) | 2 |
| 61 | 27307 | Bearing Housing (end cap) | 4 |
| 62 | 27306 | Bearing (for return rollers) | 4 |
| 63 | 28216 | Hex Shaft for return rollers 32 3/8" | 2 |

ITEM # PART # DESCRIPTION SERIAL# REQD.
BIN CONVEYOR SECTION CONT.

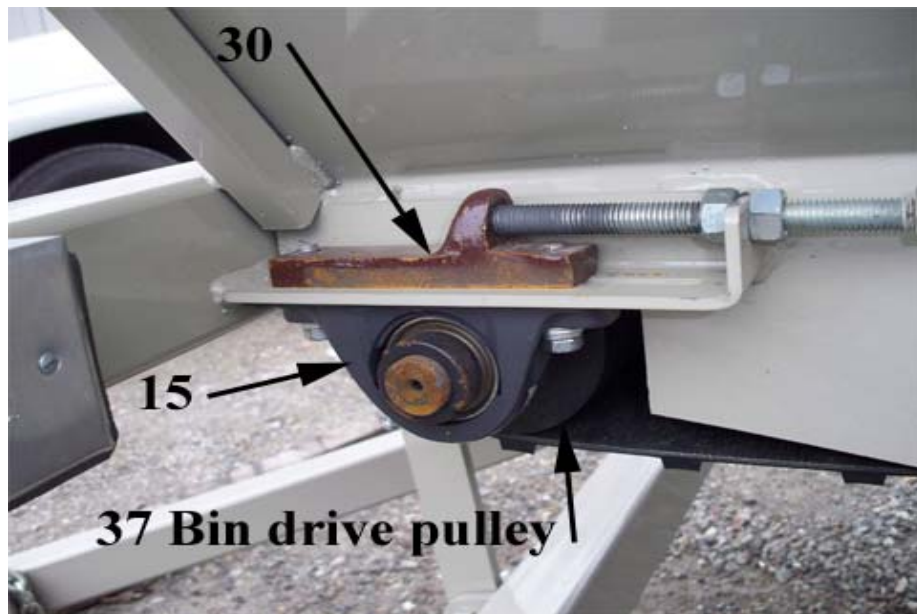
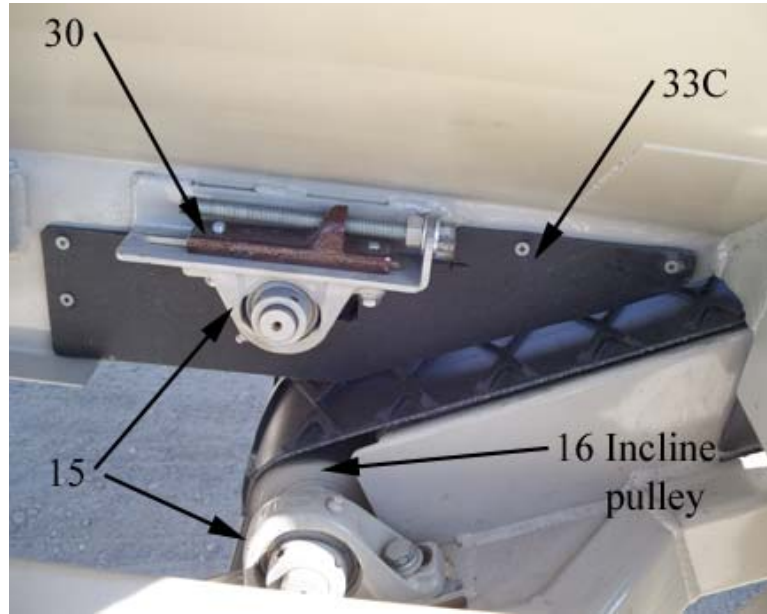

ITEM # PART # DESCRIPTION SERIAL# REQD.
BIN CONVEYOR SECTION CONT.

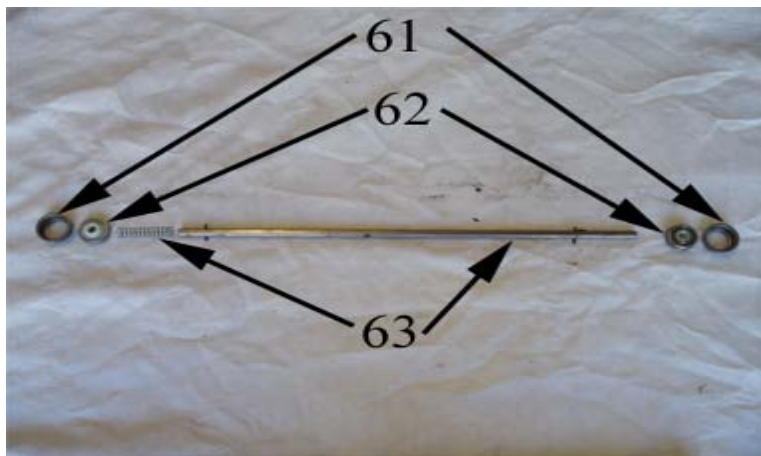
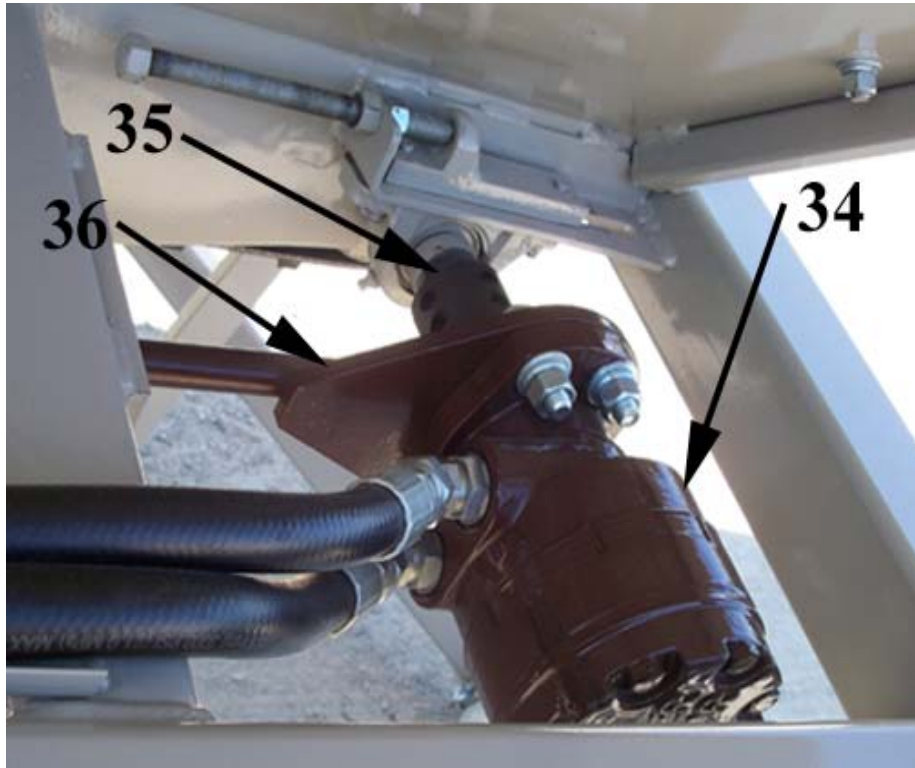

| ITEM # | PART # | DESCRIPTION | SERIAL # | REQD |
|--|---------------|--|-----------------|-------------|
| ENGINE PARTS: | | | | |
| 100 | 27014 | Air Filter Inner (Don. P829332) | | 1 |
| 101 | 27013 | Air Filter-Outer (Don. P827653) | | 1 |
| 101A | 27015 | Air Filter Assembly G0700018 | | 1 |
| 101B | 27015A | Air Filter Mounting Band P777731 | | 1 |
| 101C | 27015B | Air Filter Vacuator P158914 | | 1 |
| 102 | 27013A | End Cover (P636202) | | 1 |
| 103 | 28795 | Restriction Indicator (4235036) | | 1 |
| 104 | 27011 | Fuel Filter (Deutz 117-4696) | | 1 |
| 104A | 27943 | Fuel Strainer in line 117-8753 | | 1 |
| 105 | 27010 | Oil Filter (Deutz 117-4416) | | 1 |
| 105A | 28158 | Dip Stick (427-2816) | | 1 |
| 106 | 27168B | Fan Belt (Deutz 117-9564) | | 1 |
| 107 | 27202D | Fuel Shut off Solenoid (428-7583) | | 1 |
| 107A | 27202C | Wiring Loom for Fuel Shut Off Solenoid | | 1 |
| 109 | 27203C | Fuel Pump (428-6113), F4L2011 | | 1 |
| 109A | 27203B | O-Ring (117-9160) | | 1 |
| 110 | 28481 | Fuel Injector Return Line Kit 428-1428 | | 1 |
| Items 115 through 118 are for Duetz D2011 LO4i Engine only. | | | | |
| 115 | 27656 | Throttle Solenoid (1756E) | | 1 |
| 115A | 27654 | Solenoid Rubber Boot | | 1 |
| 116 | 27655 | Trombete Module (P515 A57 12V) | | 1 |
| 116 | 27657 | Coil Commander (SA4687) | | 1 |
| 117 | 27310 | Throttle Linkage Kit, Assembly | | 1 |
| | 24744C | Ball Joint, 90 degree | | 1 |
| | 24744D | Hex Spacer | | 1 |
| | 24744E | Straight Connection | | 1 |
| 118 | 27776 | Throttle Lever 417- 9754 | | 1 |
| Item 118A through 129 are for other series Engines. | | | | |
| 118A | 28484 | Throttle Lever | | 1 |
| 124 | 28346 | SYN. Throttle Solenoid (2370ES-12E 2ul B5) | | 1 |
| 124A | | Solenoid Rubber Boot | | 1 |
| 124B | 27657 | SYN. Coil (SA467 176) | | 1 |
| 125 | 28349 | Yoke (175 403 002-5/16-24 90deg. QD & Short) | | 1 |
| 126 | 28351 | Throttle Arm | | 1 |
| 127 | 28352 | Female Yoke End | | 1 |
| 128 | | 2-252 O Ring | | 2 |
| 129 | 28392 | Compression Spring | | 1 |
| 130 | 27803 | Alternator Rebuilt Deutz | | 1 |
| | 27803A | Alternator New 118 2434 for 2,3,4 Cyl Eng. | | 1 |
| 131 | | Starter 118 3599 | | 1 |

ITEM # PART # DESCRIPTION SERIAL# REQD.

ENGINE PARTS CONT:

Item 137 is for Duetz D2011 LO4i Engine only.

| | | | |
|-----|--------|---|---|
| 137 | 25026A | Exhaust Pipe | 1 |
| | 24752 | Exhaust Pipe Hanger 1¾" U Bolt Clamp | 1 |

Item 137A is for other series Engines.

| | | | |
|------|-------|---|--------|
| 137A | 25026 | Exhaust Pipe | |
| | 28972 | Exhaust Pipe Hanger 1¾" U Bolt Clamp | 1 1 |

| | | | |
|-----|-------|-----------------------------------|---|
| 138 | 27285 | Gas Shock for Engine Door | 1 |
| 139 | 27959 | Rubber Ring Isolator Deutz Engine | 1 |
| 142 | 22424 | Hour Meter (85002-03) | 1 |

| | | | |
|------|--------|---|---|
| 155 | 27131A | Engine Oil Temperature Gauge (118 2577) 2" hole | 1 |
| 155A | 28486 | Engine Oil Temperature Sender (118 2876) | 1 |
| 155B | 28485 | Oil Pressure Sender (117 5881) | 1 |

REPLACEMENT ENGINES & DRIVE PLATE KIT: Contact a JACKRABBIT Dealer or JACKRABBIT and supply the LOADMASTER 30/60 Serial Number.

For a complete list of engine parts see your Deutz engine parts manual.

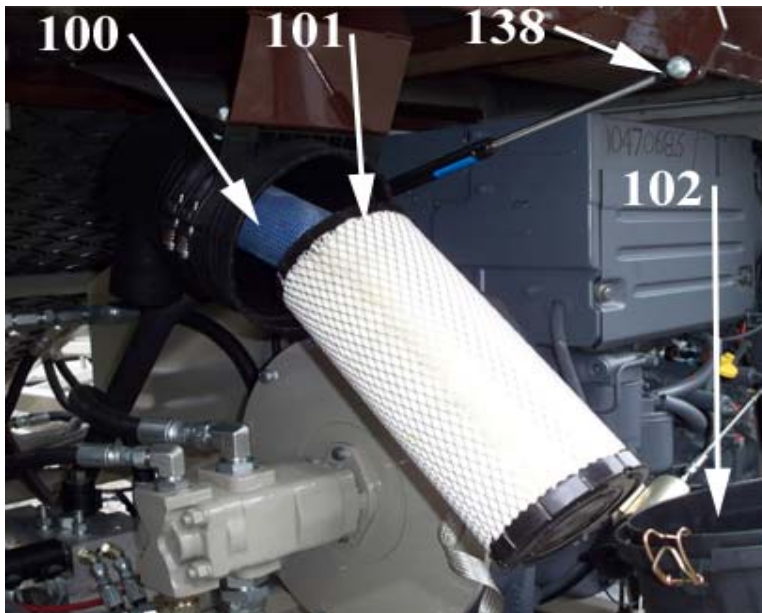

ITEM #

PART #

DESCRIPTION

SERIAL# REQD.

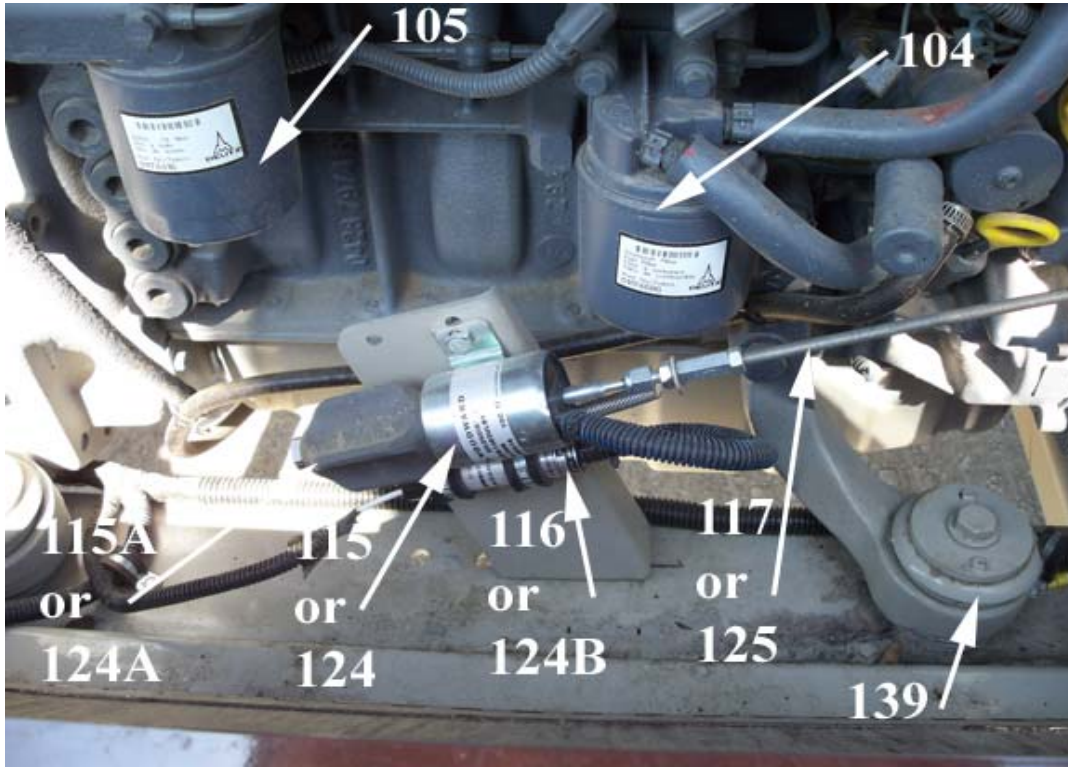

ITEM # PART # DESCRIPTION SERIAL# REQD.
ENGINE SECTION

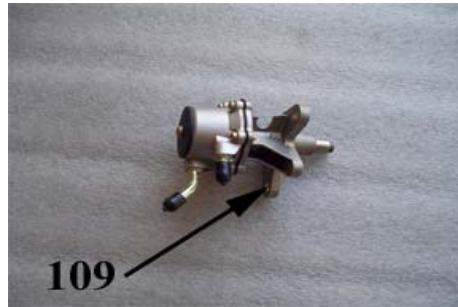

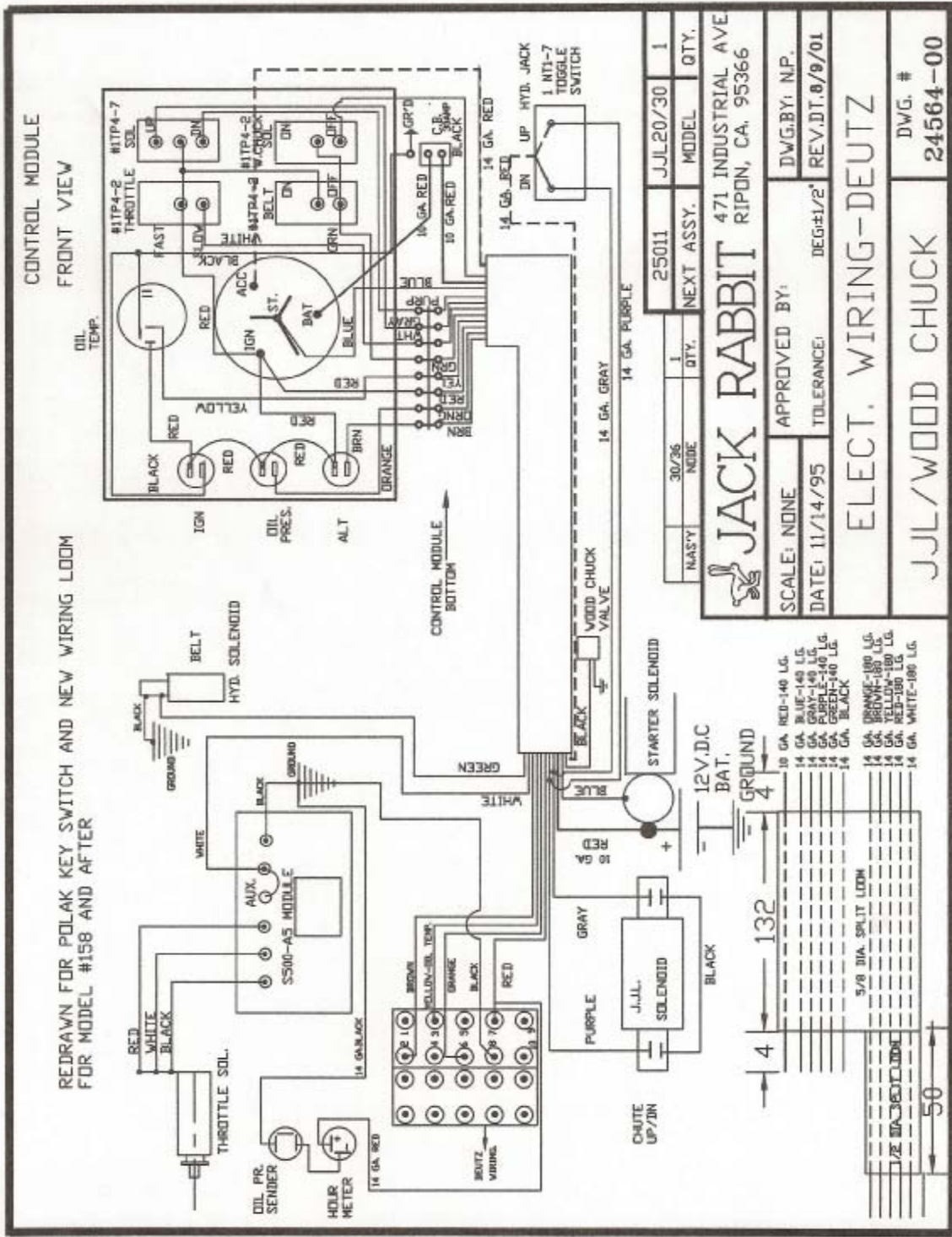

| ITEM # | PART # | DESCRIPTION | SERIAL # | REQD |
|--------------------|----------|--|----------|------|
| ELECTRICAL: | | | | |
| 150 | 26403 | Rocker Switch (1TP4-2) Throttle & Belt | | 2 |
| 151 | 27118 | Rocker Switch Momentary (#1TP4-7) Jack & WoodChuck | | 1 |
| 152 | 27527 | Toggle Switch (1TL1-2) | | 1 |
| 153 | 28213 | Toggle Switch (1NT1-7) @ end of bin | | 1 |
| 154 | 22416 | Key Switch (Polak 331-196) | | 1 |
| | 22416A | Key Polak for 22416 | | 1 |
| 155 | 27131A | Engine Oil Temperature Gauge (118 2577) 2" hole | | 1 |
| 155A | 28486 | Engine Oil Temperature Sender (118-2876) | | 1 |
| 155B | 28485 | Oil Pressure Sender (117-5881) | | 1 |
| 156 | 27145 | Deutz Idiot Light Assembly | | 1 |
| 157 | 27123 | Light Bulb Only | | 1 |
| 158 | 27787 | Circuit Breaker Cole Hersee 30055-6 5 AMP | | 1 |
| 159 | 26399 | Circuit Breaker 30 AMP | | 1 |
| 159 | | Relay | | 2 |
| 160 | 28246 | Remote Control Transmitter | | 1 |
| 160 | 28247 | Remote Control Receiver | | 1 |
| 161 | 24564-97 | Electrical Wiring Schematic for 30/60 & WoodChuck | | 1 |

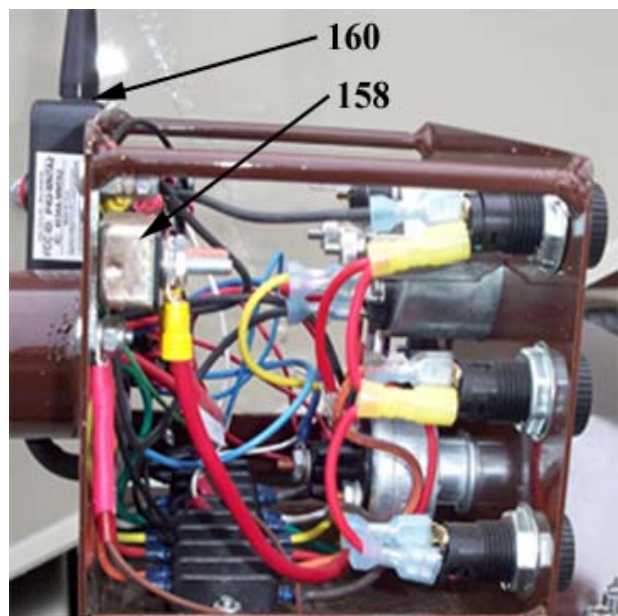
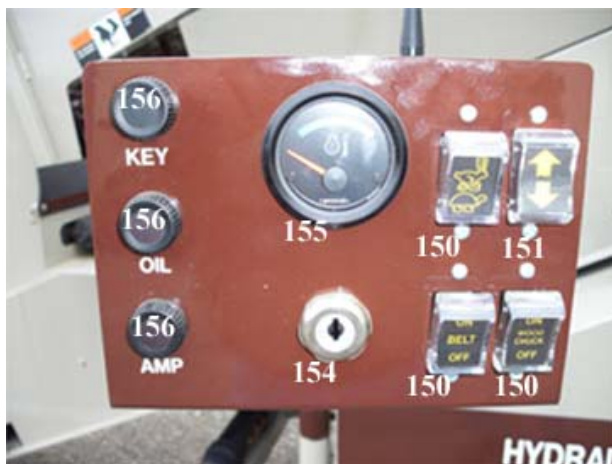

ITEM # PART # DESCRIPTION SERIAL # REQD
 HYDRAULICS: for 30/60 Elevator without WOODCHUCK dwg, 28990

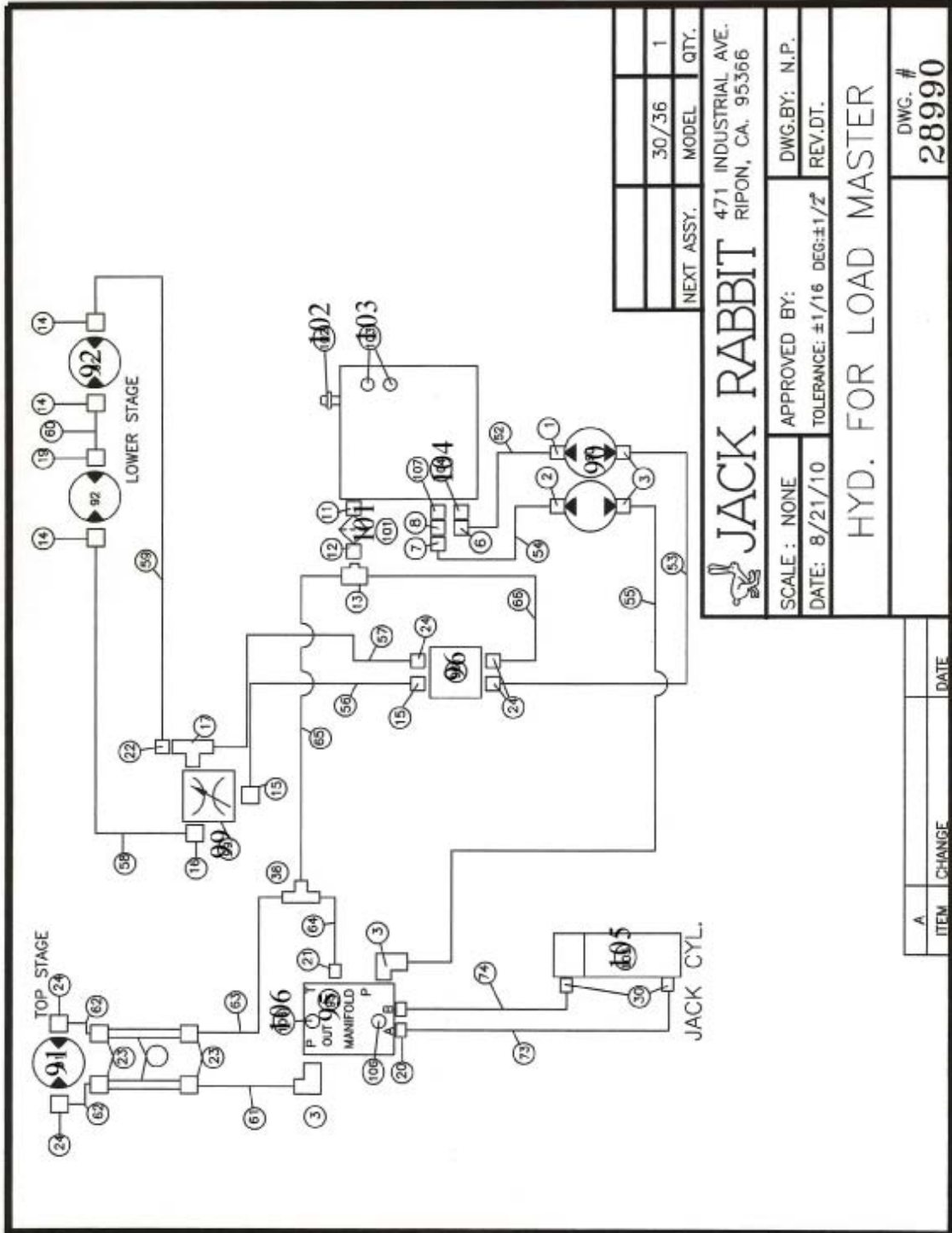

| ITEM # | # ON | PART # | DESCRIPTION | SERIAL# | REOD |
|--|-------------|---------------|--------------------------------------|----------------|-------------|
| HYDRAULICS: for 30/60 Elevator without WOODCHUCK dwg. 28990 | | | | | |
| 1 | 91 | 26034 | Incline Conveyor Motor | | 1 |
| 92 | 35 | 24664 | Bin Conveyor Motors | | 2 |
| | | 24664A | Seal kit for 24664 | | 1 |
| 180 | 101 | 27811 | Hydraulic Filter LHA SPE 60-10 | | 1 |
| 182 | 104 | 24671 | Suction Strainer | | 1 |
| 185 | 90 | 28994 | Pump (Double Pump) P3301--- | | 1 |
| 186 | | 24641 | Lower pin for 26612 | | 1 |
| 187 | 105 | 26612 | Cylinder (2" x 24") for jack | | 1 |
| 188 | 95 | 26050 | Manifold 8051-1 | | 1 |
| | | 96 | C-33996 HZ Belt Body | | 1 |
| 193 | 99 | 24403 | Flow Control (FC 51-3/4) | | 1 |
| 195 | 102 | 27182 | Hydraulic Tank Filler Cap & Breather | | 1 |
| 196 | | 26199 | Clamp (1" Hycon double) | | 8 |
| | | | Clamp (3/4" Hycon double) | | 2 |
| 197 | 103 | 24669 | Sight Gauge | | 2 |
| | 106 | | Test Fitting | | 1 |

The other numbers shown on drawing 28990 and not listed above are for hoses and fittings.

| | | | | | |
|-----|--|-------|----------------------------------|--|--|
| 188 | | 26050 | Manifold Components: | | |
| | | 27317 | Flow Control FRDA XAN | | |
| | | | SV 10-47A-0-N-00 | | |
| | | | Hydraforce 6351012-12V Coil | | |
| | | | Hydraforce SV16-23-0-N-00 (BELT) | | |
| | | 27314 | Relief Valve RPEC - FAN | | |
| | | | RPGC-FAN CART VALVE | | |
| | | | C-33996 HZ Belt Body | | |
| | | | SV12-21 0-N -00 Cartridge | | |
| | | | RV12-26A -N-35 | | |

ITEM # PART # DESCRIPTION SERIAL # REQD
 HYDRAULICS: for 30/60 Elevator with WOODCHUCK dwg. 28991

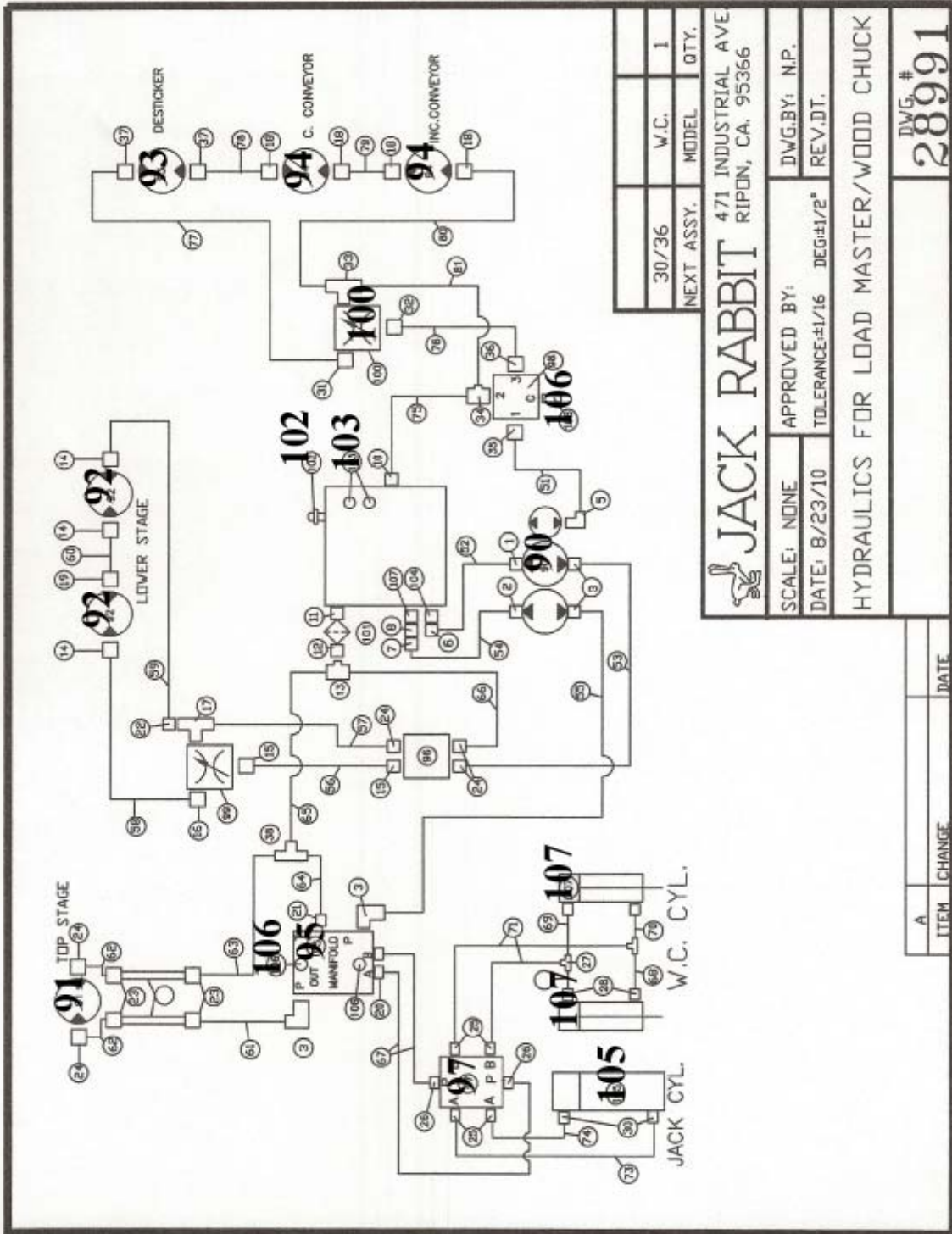

| | | |
|------------|-------|------|
| 30/36 | W.C. | 1 |
| NEXT ASSY. | MODEL | QTY. |

JACK RABBIT
 471 INDUSTRIAL AVE
 RIPON, CA. 95366

SCALE: NONE
 DATE: 8/23/10
 APPROVED BY: N.P.
 TOLERANCE: ±1/16 DEG: ±1/2°
 REV.DT.

HYDRAULICS FOR LOAD MASTER/WOOD CHUCK

DWG. #
28991

| A | CHANGE | DATE |
|---|--------|------|
| | | |

| ITEM # | # ON | PART # | DESCRIPTION | SERIAL# | REQD |
|---|-------------|---------------|--|----------------|-------------|
| HYDRAULICS: for 30/60 Elevator with WOODCHUCK dwg. 28991 | | | | | |
| 1 | 91 | 26034 | Incline Conveyor Motor | | 1 |
| 35 | 92 | 24664 | Bin Conveyor Motors | | 2 |
| | | 24664A | Seal kit for 24664 | | 1 |
| 180 | 101 | 27811 | Hydraulic Filter LHA SPE 60-10 | | 1 |
| 182 | 104 | 24671 | Suction Strainer | | 1 |
| 185 | 90 | 28989 | Pump (Triple Pump) | | 1 |
| 186 | | 24641 | Lower pin for 26612 | | 1 |
| 187 | 105 | 26612 | Cylinder (2" x 24") Jack | | 1 |
| 188 | 95 | 26050 | Manifold 8051-1 | | 1 |
| | | 96 | C-33996 HZ Belt Body | | 1 |
| 191 | 97 | 27573 | Selector Valve (DH5/6B-SAE) | | 1 |
| | | 98 | Sun XRCX-LAN-HJ-712 Vented relief | | 1 |
| 193 | 99 | 24403 | Flow Control (FC 51-12SAE) | | 2 |
| 194 | 100 | 28999 | Flow Control (FC 51-10 SAE) | | 1 |
| 195 | 102 | 27182 | Hydraulic Tank Filler Cap & Breather | | 1 |
| 196 | | 26199 | Clamp (1" Hycon double) | | 4 |
| | | | Clamp (3/4" Hycon double) | | 1 |
| 197 | 103 | 24669 | Sight Gauge | | 2 |
| | 106 | | Test Fitting | | 1 |
| 198 | 107 | 28937 | Cylinder 1 1/2"x 6" (lifts & lowers WoodChuck) | | 2 |

The other numbers shown on drawing 28991 and not listed above are for hoses and fittings.

| | | | | | |
|-----|-----|-------|----------------------------------|--|--|
| 188 | 95 | 26050 | Manifold Components: | | |
| | | 27317 | Flow Control FRDA XAN | | |
| | | | SV 10-47A-0-N-00 | | |
| | | | Hydraforce 6351012-12V Coil | | |
| | | | Hydraforce SV16-23-0-N-00 (BELT) | | |
| | | 27314 | Relief Valve RPEC - FAN | | |
| | | | RPGC-FAN CART VALVE | | |
| | 96 | | C-33996 HZ Belt Body | | |
| | | | SV12-21 0-N-00 Cartridge | | |
| | | | RV12-26A -N-35 | | |
| | 98 | | Sun XRCX-LAN-HJ-712 Vent relief | | |
| | 99 | | FC51-12 SAE (HZ Belt) | | |
| | 100 | | FC51-10 SAE | | |

ITEM # PART # DESCRIPTION SERIAL # REQD
HYDRAULICS:

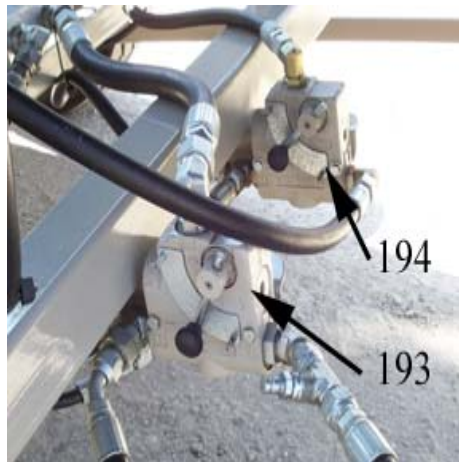
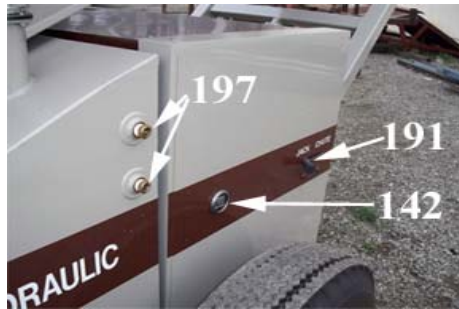
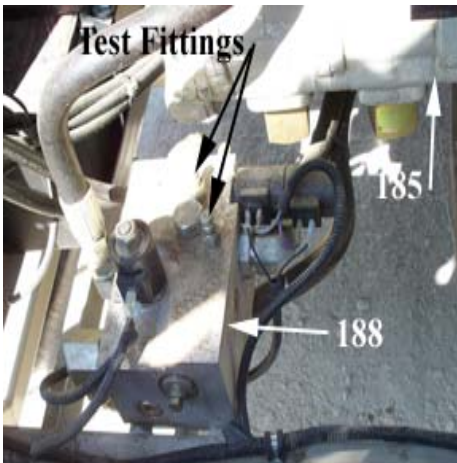
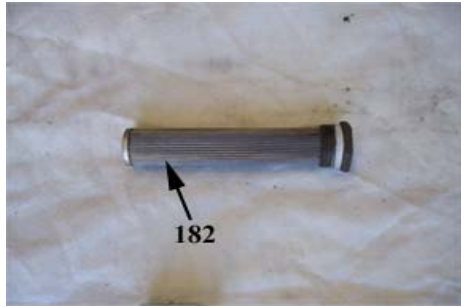

| ITEM # | PART # | DESCRIPTION | SERIAL # | REQD |
|-----------------------------|-------------------------|---|-----------------|-------------|
| BEARINGS: | | | | |
| 5 | 22097 | Bearing (1-1/2" Pillow Block) | | 2 |
| 8 | 23524 | Flangette Bearing (#52 MST 22PPRAG) | | 2 |
| 15 | 22977 | Bearing (1" Pillow Block) | | 6 |
| 15B | 31067 | Bearing (#RFC #1-1/2") | | 2 |
| 10 | 27306 | Bearings For Return Rollers | | 16 |
| 30 | 26464 | Bearings Pad | | 8 |
| BELTS | | | | |
| 9 | 28892 | 36" x 64' – 6" Giant Z Belt (Incline) Standard Model | | 1 |
| | 29131 | 36" x 70' 6" Giant Z Incline Belt (3' Extension) option | | 1 |
| | 27523C | 36" Pin for Lacing | | 1 |
| 33 | 28891 | 30" x 309" Giant Z Bin Belt | | 1 |
| | 27523A | 30" pin for Lacing | | 1 |
| DECALS: | | | | |
| 300 | | | | |
| | 24537 | JACLRABBIT (White) | | 1 |
| | 24538 | JACKRABBIT (Brown) | | 2 |
| | 24546 | DIESEL (White) | | 1 |
| | 24546A | DIESEL (Brown) | | 1 |
| | 24548 | HYDRAULIC (White) | | 1 |
| | 24548A | HYDRAULIC (Brown) | | 1 |
| | 24986 | CONTROL PANEL | | 1 |
| | 24637 | OIL, IGN, ALT, White Decals | | 1 |
| | 27529 | Switch Name Plate Insert | | 1 |
| MISCELLANEOUS PARTS: | | | | |
| 349 | 28834 | Axel Assembly | | |
| 350 | 27020 | Tires 12-16.5 TL R-3 | | 2 |
| | 28917 | Rims 16.5 x 9.75 | | 2 |
| | 24751 | Fuel Cap #703-1060 | | 1 |
| | 27285 | Gas Shock | | 1 |
| | Paint and Primer | | | |
| | 25750 | Beige Touch Up | | 1 |
| | 25750A | Brown Touch Up | | 1 |
| | 27552 | Primer, mixed | | 1 |
| | 27552-1 | Primer, 1 gal. | | 1 |
| | 27552-2 | Activator 1 gal. | | 1 |
| | 27552-A | Beige, mixed 1 gal. | | 1 |
| | 27552-AA | Beige, not mixed 3/4 gal. | | 1 |
| | 27552-B | Brown, mixed 1 gal. | | 1 |
| | 27552-BB | Brown, not mixed 3/4 gal | | 1 |
| | 27552-C | Hardener 1 pt. | | 1 |
| | 27552D | Enhancer, pt. | | 1 |

WOODCHUCK

| ITEM # | PART # | DESCRIPTION | SERIAL # | REQD |
|---------------|---------------|--------------------|-----------------|-------------|
|---------------|---------------|--------------------|-----------------|-------------|

BEARINGS & SPROCKETS:

| | | | | |
|-----|-------|---|--|----|
| 400 | 22977 | VAK 1" Pillow Block Bearing | | 10 |
| 401 | 26201 | 6T 550 Eccentric Sprocket W/Bearing 5/8" Bore | | 4 |
| 404 | 22983 | 8T 550 Idler -5/8" Bore G&G | | 4 |
| 405 | 26202 | 11T 550 1" ID Sprocket | | 4 |

BELTS:

| | | | | |
|-----|--------|--|--|---|
| 410 | 27380 | (12" x 196") Giant Z Incline Belt, Almonds & Walnuts | | 1 |
| 411 | 27378 | (12" x 115" Giant Z Incline Belt, Almonds & Walnuts | | 1 |
| 413 | | (30"x) Giant Z DS30 Cross Conv. Pecan | | 1 |
| 415 | 27523A | 30" Lacing Pin | | 1 |
| | 27523B | 12" Lacing Pin | | 1 |

CHAIN:

| | | | | |
|-----|-------|--------------------------------------|--|---|
| 420 | 28530 | Desticker Chain Weldment | | 1 |
| 421 | 28531 | Desticker Master Link Bar W/5 Flags | | 1 |
| 422 | 28532 | Desticker Master Link Bar W/ 4 Flags | | 1 |
| 423 | 28529 | Desticker Master Link Bar W/Fingers | | 1 |
| 424 | 26046 | Flags (Only) | | 1 |
| 425 | 27141 | CA 557 Master Link No Attachment | | 1 |
| 427 | 27142 | CA 557 Master Link W/A4 Attachment | | 1 |

When the desticker chain is replaced, all the sprockets, slides, and seals should also be replaced.

HYDRAULICS:

| | | | | |
|-----|--------|--|--|---|
| 430 | 24664 | DS Drive Motor (RS #180201) | | 1 |
| | 24664A | Seal Kit for (RS #180201) | | 1 |
| 431 | 27017 | Conveyor Drive Motor (RS #100201) | | 2 |
| 432 | 26050 | Manifold Duel Flow | | 1 |
| 433 | 27313 | Solenoid Valve Waterman 15C7TS | | 1 |
| 434 | 27317 | Relief Valve FRDA XAN | | 1 |
| 435 | 27318 | Coil 70402S-12 | | 1 |
| 436 | 28937 | Cylinder (1 1/2" x 6"), lifts & lowers WoodChuck | | 2 |

| ITEM # | PART # | DESCRIPTION | SERIAL # | REQD |
|---|---------------|--|-----------------|-------------|
| MISCELLANEOUS PARTS: | | | | |
| 450 | 26692 | Rubber Stick Bumper | | 1 |
| 451 | 27583 | WARNING (Decal) | | 2 |
| 452 | 26231 | Shield for Sprockets, UHMW | | 2 |
| 453 | 26232 | Outer Shield for Sprockets, Metal | | 4 |
| PULLEYS, SHAFTS, COUPLERS, TORQUE ARMS: DS 36 WoodChuck: | | | | |
| 460 | 26158 | Drive Pulley (Conveyor) 2.08" X 12" | | 2 |
| 461 | 26157 | Idler Pulley (Conveyor) 2.08" X 12" | | 2 |
| 464 | 27536 | Drive Pulley (Conveyor) SRC 2.08"X 30" Pecan | | 1 |
| 465 | 27538 | Idler Pulley (Conveyor) 2.08 X 30" Pecan | | 1 |
| 466 | 28896 | 1" Drive Shaft X 40 3/4" | | 1 |
| 467 | 28897 | 1" Idler Shaft X 36 1/4" | | 1 |
| 468 | 26493 | Climax Coupler 1" (CC-100-100) | | 3 |
| 469 | 24395D | Torque Arm, WoodChuck | | 1 |
| | 24395E | Torque Arm, Conveyors | | 2 |
| SLIDES & SEALS: | | | | |
| 33C | 28934 | Transition Seal, UHMW | | 2 |
| 470 | 26622 | Side Seal 6" x 24" | | 2 |
| 471 | 27373 | Slide Kit (#472-475) | | 1 |
| 472 | 22190 | 1/4" x 3/4" Elevator Bolts, Nuts & Washers | | 28 |
| 473 | 26129 | Upper Chain Slide | | 4 |
| 474 | 25386 | Short Upper Slide | | 4 |
| 475 | 24491 | Exhaust Slide (Incline) | | 2 |
| 480 | 28552A | Cross Conveyor Seal, 4" X 96" | | 1 |

| ITEM # | PART # | DESCRIPTION | SERIAL # | REQD |
|--------|--------|-------------|----------|------|
|--------|--------|-------------|----------|------|

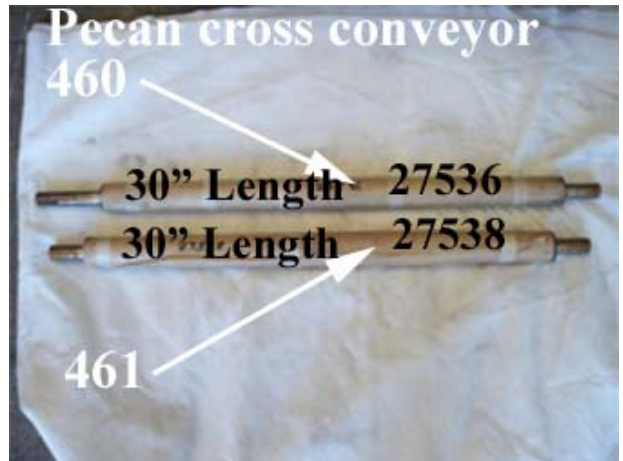
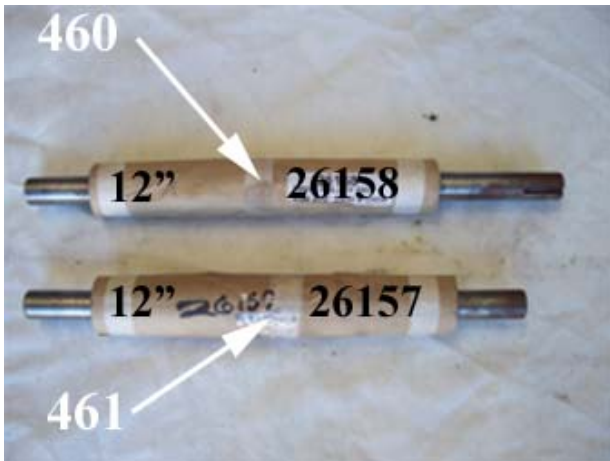
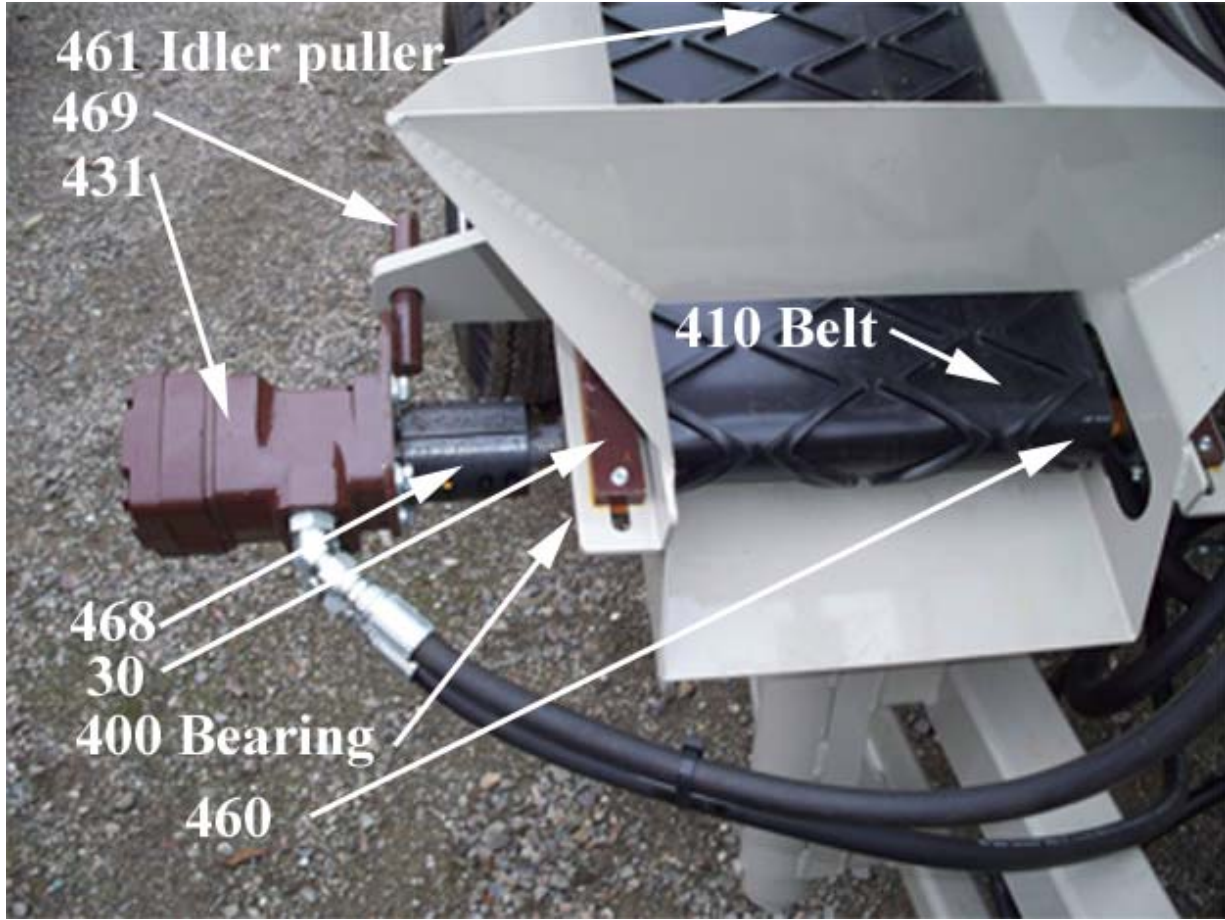

ITEM # PART # DESCRIPTION SERIAL # REQD

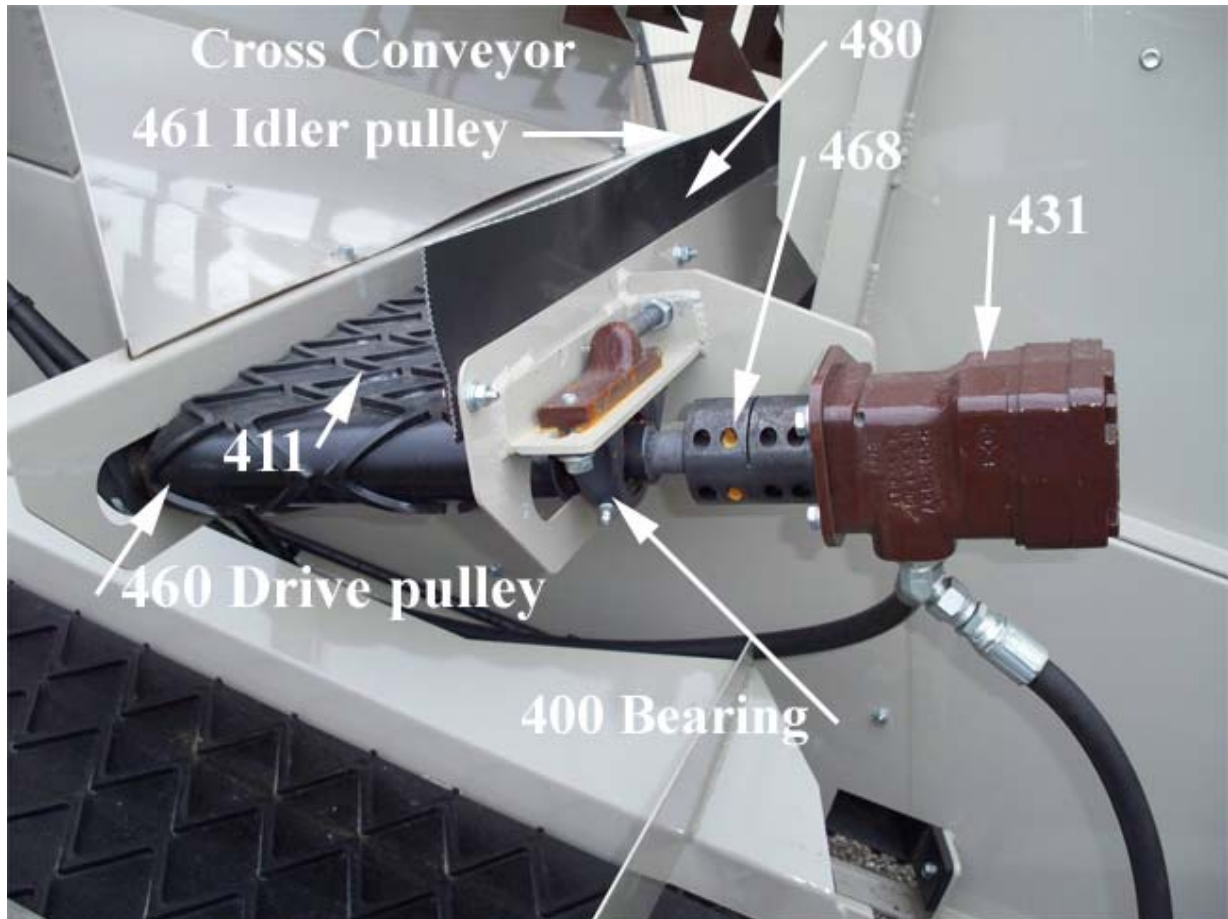

WOODCHUCK

ITEM # PART # DESCRIPTION SERIAL # REQD

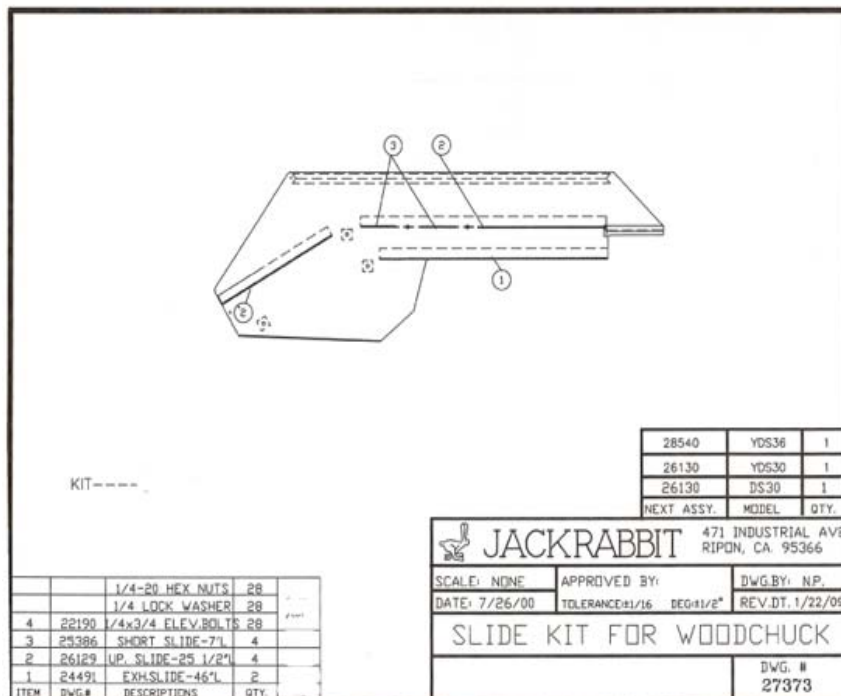
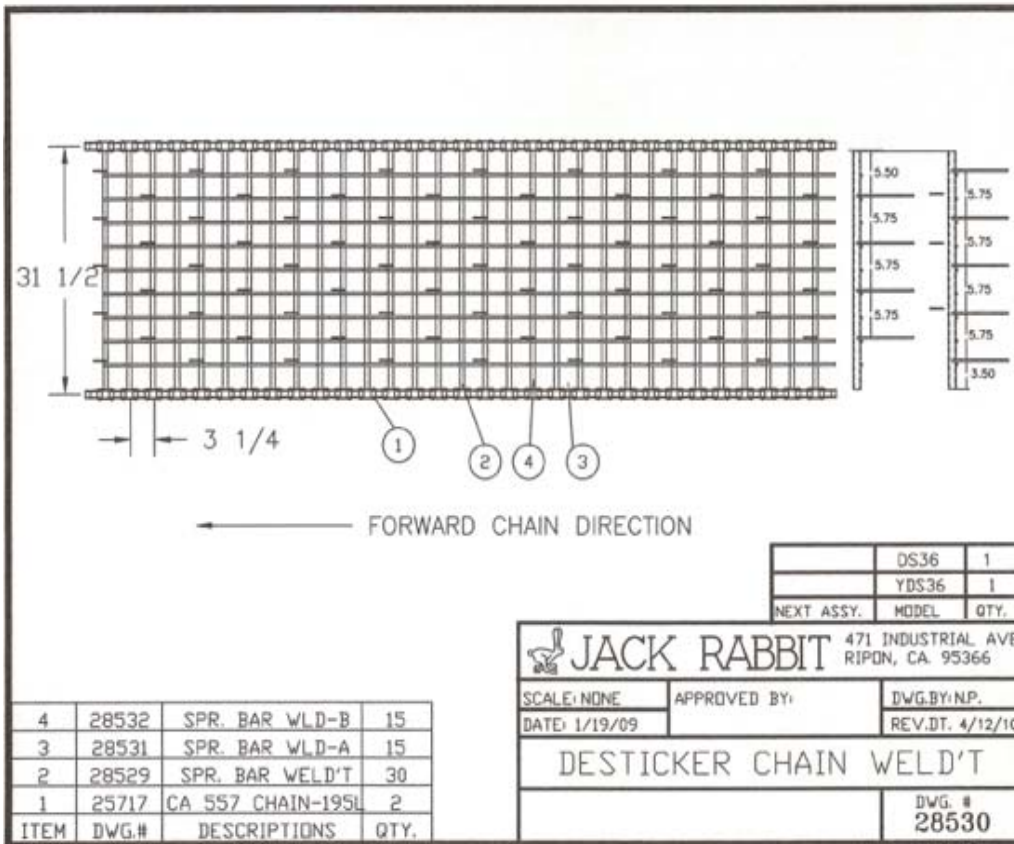

WOODCHUCK

ITEM # PART # DESCRIPTION SERIAL # REOD

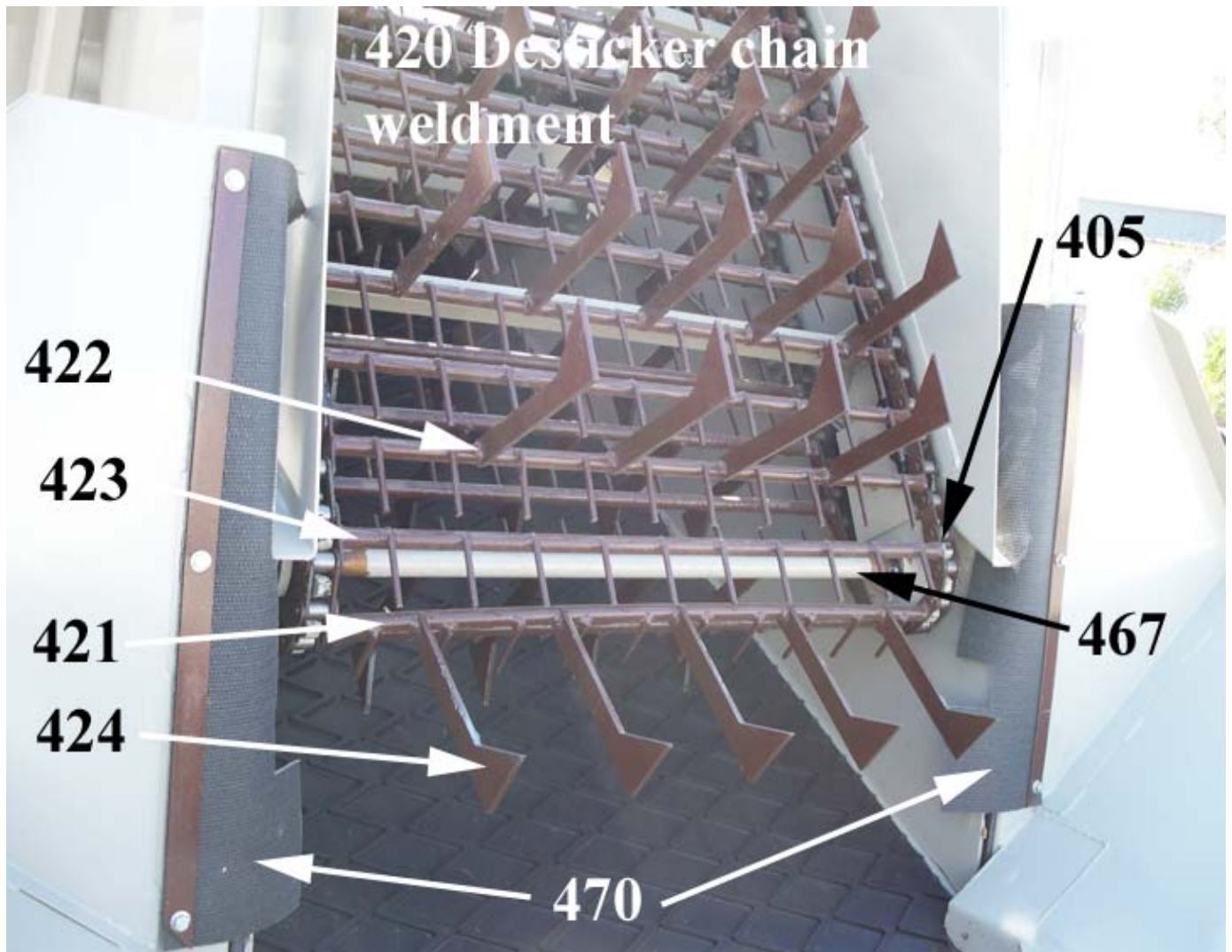

421,422, 423 & 424 are repair parts for the Desticker chain weldment.

467 is Idler shaft

405 is sprocket for 557 roller chain

WOODCHUCK

ITEM # PART # DESCRIPTION SERIAL # REQD

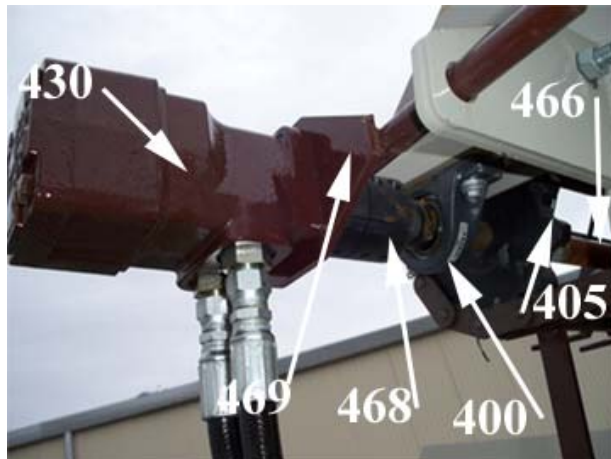
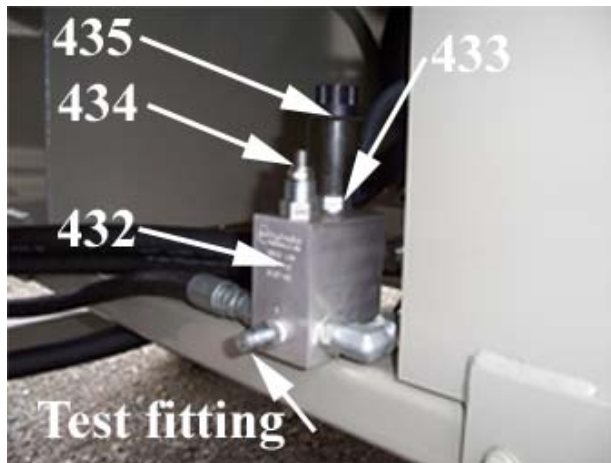

ITEM # PART # DESCRIPTION SERIAL # REQD

FRONT WHEEL, ASSEMBLIES

501 28240 Front Spindle Plate Assembly

1

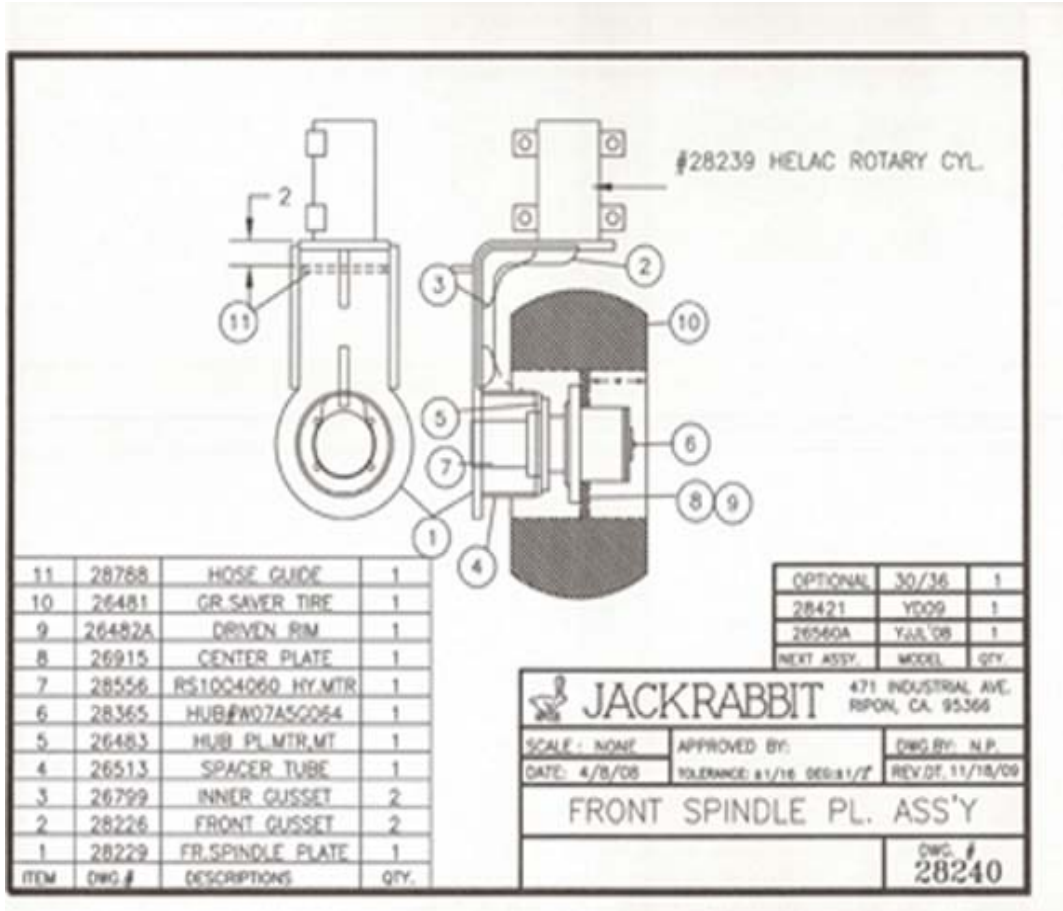

| ITEM # | PART # | DESCRIPTION | SERIAL# | REQD. |
|--------------------------------|--------|----------------------------|---------|-------|
| FRONT WHEEL, ASSEMBLIES | | | | |
| 502 | 28238 | Steering Cylinder Assembly | | 1 |

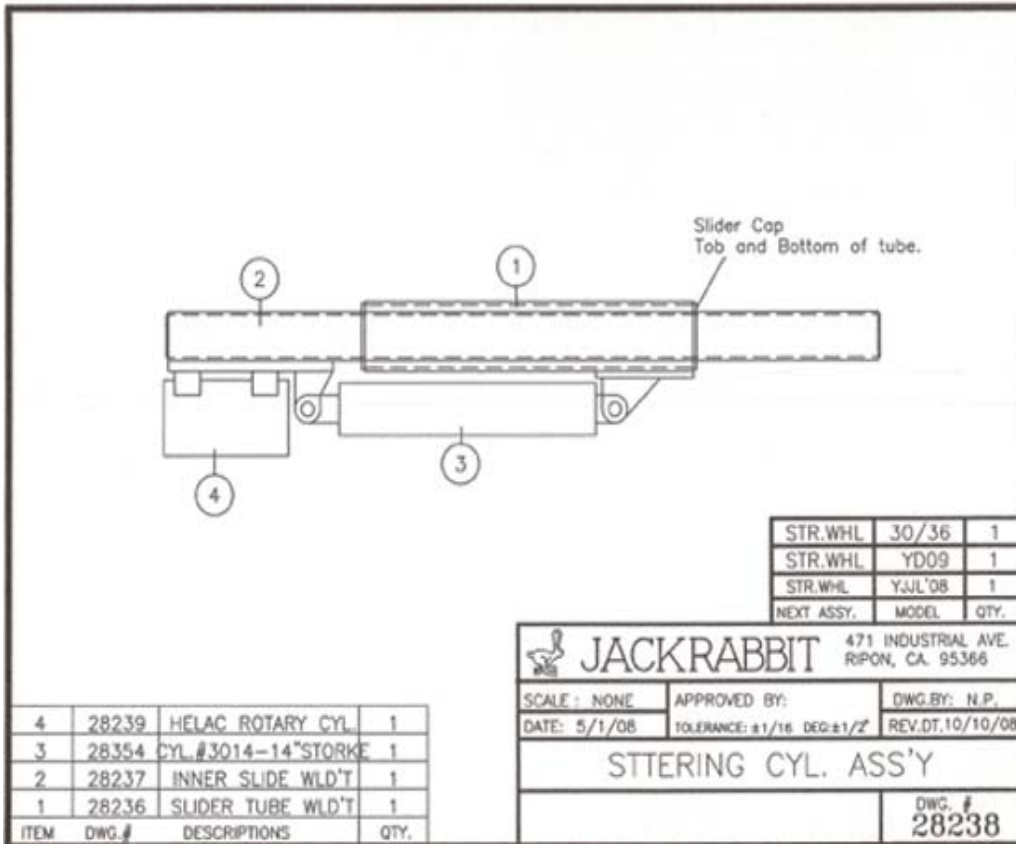

| | | | |
|------|-------|---|---|
| 502A | 28317 | UHMW Internal Spacer for slide tube (1/2" x 3 7/8" x 25 7/8") | 4 |
| 503 | 27354 | Cylinder CTRE 2008 | 1 |

ITEM #

PART #

DESCRIPTION

SERIAL# REQD.

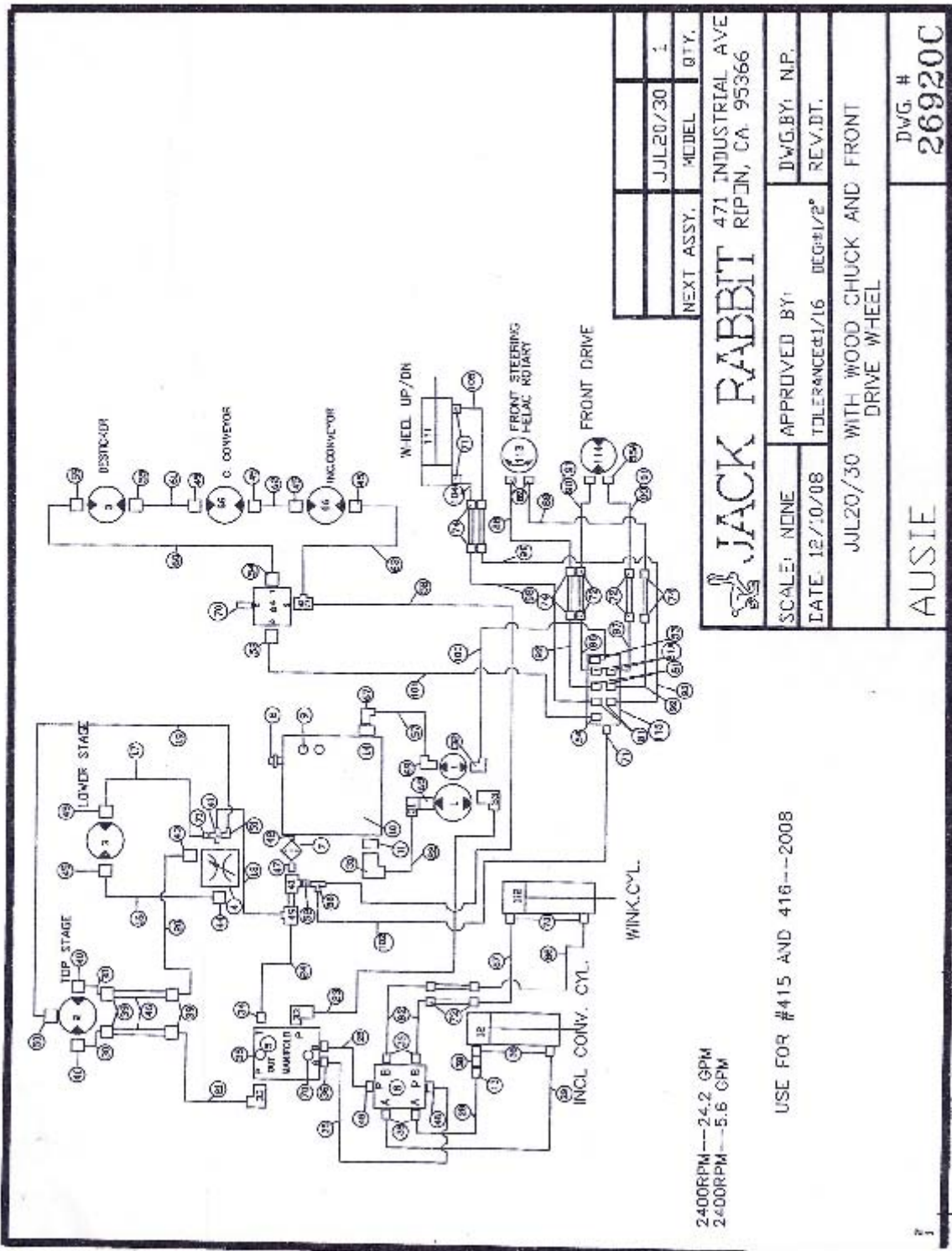

2400RPM--24.2 GPM
 2400RPM--5.6 GPM

USE FOR #415 AND 416--2008

| | | |
|------------|----------|------|
| NEXT ASSY. | JUL20/30 | QTY. |
| MODEL | | 1 |

JACK RABBIT
 471 INDUSTRIAL AVE
 RIPEN, CA. 95366

SCALE: NONE
 DATE: 12/10/08
 APPROVED BY: DWG.BY: N.P.
 TOLERANCE: 1/16 DEC: 1/2" REV.DT.

JUL20/30 WITH WOOD CHUCK AND FRONT DRIVE WHEEL

AUSIE
 DWG. # 26920C